

SHOWBEAM 2.5

Automated wash luminaire



Key Benefits

- 2500 watt wash light
- CMY color mixing with variable CTO
- Fast 11 to 33 degree zoom
- Innovative Twin Beam effect
- RGB LED tracking ring

The High End Systems SHOWBEAM 2.5 automated wash luminaire features a jointly developed Philips MSR 2500-watt lamp source. A smooth field, soft-edge illumination is produced using a new radial lenticular homogenizing lens system that provides the fixture with a signature look on stage. In addition, the dedicated wash light includes a user changeable fixed color wheel, a variable CTO, a full CMY color mixing system and the ability to produce an 11-degree fixed hard-edge profile with fast color change and Electronic Strobe. The hard/soft-edge profile can be rapidly zoomed from 11 to 33 degrees.

A revolutionary patent pending effect, the Twin Beam™, can be produced whereby two discrete hard-edge beams exit the fixture upon operator command, with variable control over the Twin Beam deviation and rotation speed with little degradation of brightness. The Twin Beam can also be varied by adding incremental color via the CMY color mixing system. SHOWBEAM 2.5 incorporates the renowned LED tracking system that encircles the lens, a feature that debuted with its SHOWGUN predecessor.

HIGH END SYSTEMS



BARCO

Visibly yours

SHOWBEAM 2.5 Technical Specifications

MECHANICAL SPECIFICATIONS

Dimensions: 596 x 605 x 925mm, 23.5 x 23.8 x 36.4in.

Fixture Weight: 66.2 kg (146 lb)

ELECTRICAL SPECIFICATIONS/LIGHT SOURCE

Power Consumption: 18 Amps at 200V, 15 Amps at 240V

Lamp: PHILIPS MSR 2500/2 SA

Power: 2500W

Color Temperature: 7000K

OPERATION

Pan: 420°

Tilt: 216°

Zoom Range: 11°- 33°

Fixture Output: 140,000 Lumens*

Twin Beam: Optically separates the single beam into two discrete beams with variable control

DMX/RDM Connectors: 5-pin XLR

Compliances: ETL, CE

*3 points (center, middle, and edge)

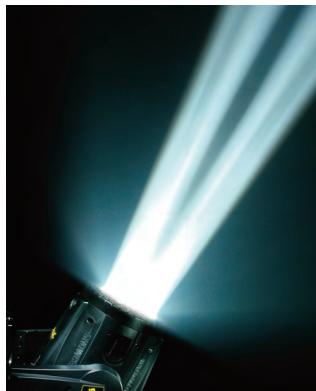
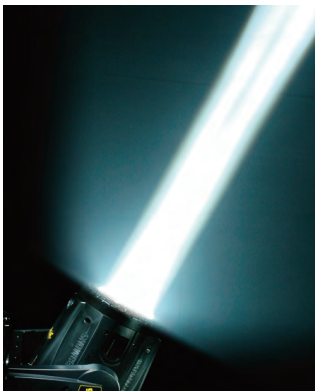
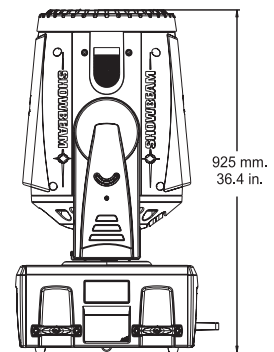
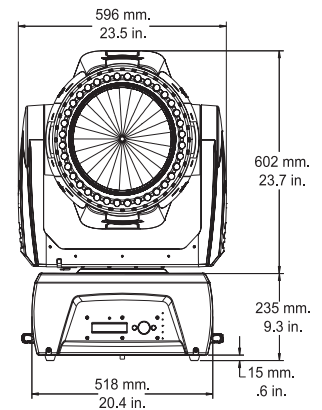
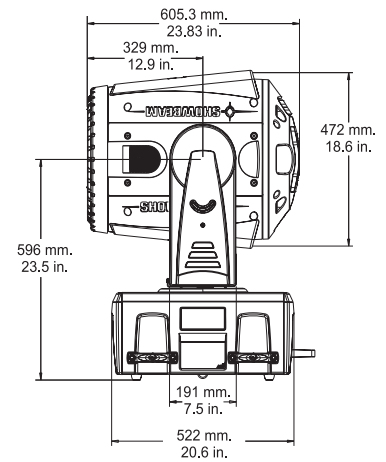

HIGH END SYSTEMS



www.barco.com
www.highend.com

Barco nv

Media & Entertainment Division
Noordlaan 5, 8520 Kuurne - Belgium
Tel. +32 56 36 80 47 - Fax +32 56 36 83 86
email: sales.events@barco.com

Barco Lighting Systems, Inc.

Media & Entertainment Division
2105 Gracy Farms Lane, Austin, TX 78758
Tel. 512 836 2242 - Fax 512 837 5290
email: sales@highend.com

BARCO

Visibly yours